

SUPERSTAR

AM/FM/USB/LSB/CW Amateur Mobile Transceiver with Built-in Frequency Counter

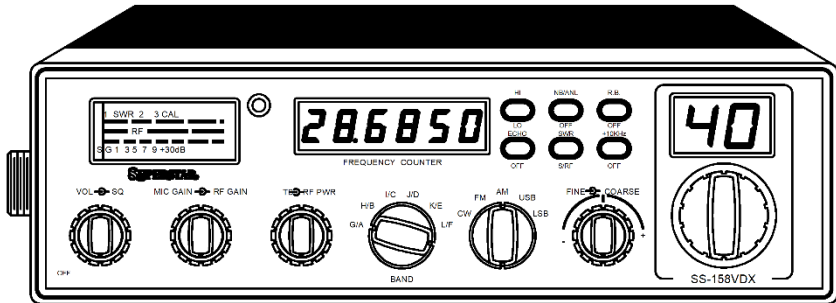

SS-158VDX

OWNER'S MANUAL

TABLE OF CONTENTS

	PAGE
CHAPTER 1	
Specifications	2
CHAPTER 2	
Installation	3
Location	3
Mounting The Radio	3
Ignition Noise Interference	4
Antenna	4
Tuning The Antenna for Optimum SWR	5
External Speaker	6
CHAPTER 3	
Operation	7
Front Panel	7
Rear Panel	9
Procedure to Receive And Transmit	10
Receiving SSB Signals	11
Alternate Microphone And Installation	13

CHAPTER 1 SPECIFICATIONS

GENERAL

Model	SS-158VDX
Frequency Range	28.245 ~ 29.655 MHz
Frequency Control	Phase-Lock-loop (PLL) Synthesizer
Frequency Stability	0.001%
Temperature Range	-30°C to +50°C
Antenna Impedance	50 Ohms
Antenna Connectors	Standard SO-239 type
Input Voltage	13.8V DC
Size	7 7/8" (W) x 10 3/4" (D) x 2 3/8" (H)
Weight	5.0 lbs

TRANSMITTER

RF Power Output	AM/FM/CW: 10W; SSB: 25W PEP
Carrier Emission	-50 dB
Spurious Emission	-50 dB
Audio Distortion	10%
Frequency Response	300 to 2500 Hz
Microphone	Dynamic

RECEIVER

Sensitivity for 10 dB (S+N)/N	CW/AM : < 1.0 μ V ; SSB : < 0.25 μ V
Sensitivity for 20 dB (S+N)/N	FM : < 0.5 μ V
Squelch Sensitivity	< 0.5 μ V
Image Rejection	More than 65 dB
AGC Figure of Merit	100 mV for 10dB Change in Audio Output
Audio Power Output	2.5W @ 10% Distortion
Audio Response	300 to 2500 Hz

(SPECIFICATIONS SUBJECT TO CHANGE WITHOUT NOTICE)

CHAPTER 2 INSTALLATION

LOCATION

Plan the location of the transceiver and microphone bracket before starting the installation. Select a location that is convenient for operation and does not interfere with the driver or passengers in the automobiles, the transceiver is usually mounted the dash panel with the microphone bracket beside it.

MOUNTING THE RADIO

The transceiver is supplied with a universal mounting bracket. When mounting the bracket and radio to your car, make sure it is mechanically strong. Also provide a good electrical connection to the chassis of the vehicle. Proceed as follows to mount the transceiver:

1. After you have determined the most convenient location in your vehicle, hold the transceiver with mounting bracket in the exact location desired. If nothing will interfere with mounting it in the desired position remove the mounting bolts. Before drilling the holes, make sure nothing will interfere with the installation of the mounting bolts.
2. Connect the antenna cable plug to the standard receptacle on the rear panel. Most transceiver antennas are terminated with a type PL-259 plug and mate with the receptacle.
3. Connect the red DC power input wire (with the fuse) to +13.8V DC. This wire extends from the rear panel. In automobile installation, +13.8V DC is usually obtained from the accessory contact on the ignition switch. This prevent the set being left on accidentally when the driver leaves the car and also permits operating the unit without the engine running. Locate the accessory contact on most ignition switches by tracing the power wire from the AM broadcast receiver in the car.
4. Connect the black lead to -13.8V DC. This is usually the chassis of the car. Any convenient location with good electrical contact (remove paint) may be used.
5. Mount the microphone bracket on the right side of the transceiver, using two screws supplied. When mounting in an automobile, place the bracket under the dash so that microphone is readily accessible.

IGNITION NOISE INTERFERENCE

Use of a mobile receiver at low signal levels is normally limited by the presence of electrical noise. The primary source of noise in automobile installation is from the generator and ignition system in the vehicle. Under most operating conditions, when signal level is adequate, the background noise does not present a serious problem. Also, when extremely low level signals are being received, the transceiver may be operated with vehicles engine turned off. The unit requires very little current and therefore will not significantly discharge the vehicle battery.

Even though the transceiver has ANL and NB controls, in some installation ignition interference may be high enough to make good communications impossible. The electrical noise may come from several sources. Many possibilities exist, as variations between vehicles require different solutions to reduce the noise.

ANTENNA

A vertically polarized, quarter-wavelength whip antenna provides the most reliable operation and greatest range. Shorter, loaded-type whip antennas are more attractive, compact and adequate for applications where the maximum possible distance is not required. Also, loaded whips do not present the problems of high wind resistant imposed by a full quarter-wavelength whip.

Mobile whip antennas utilize the metal body of the vehicle as a ground plane. When mounted at a corner of the vehicle they are slightly directional, in the direction of the body of the vehicle. For all practical purpose, however, the radiation pattern is nondirectional. The slight directional characteristic will be observed only at extreme distances. A standard antenna connector (type SO-239) is provided on the transceiver for easy connection to a standard PL-259 cable termination.

If the transceiver is not mounted on a metal surface, it is necessary to run a separate ground wire from the unit to good metal electrical ground in the vehicle. When installed in a boat, the transceiver will not operate at maximum efficiency without a ground plate, unless the vessel has a steel hull.

Before installing the transceiver in a boat, consult your dealer for information regarding an adequate grounding system and prevention of electrolysis between fittings in the hull and water.

TUNING THE ANTENNA FOR OPTIMUM S.W.R

Since there is such a wide variety of base and mobile antennas, this section will strictly concern itself to the various types of mobile adjustable antennas.

Because the antenna length is directly related to the channel frequency, it must be tuned to resonate optimally on all channels of the transceiver. Low channel (CH1) requires a longer antenna than high channel (CH40) because it is lower in its frequency of operation.

Due to the various methods of adjusting antennas for proper S.W.R. we have chosen what we think is the optimum method:

A. Antenna with adjustment screws (set screws).

1. Starts with the antenna extended and tighten the set screw lightly enough so that the antenna can be lightly tapped with your finger for easy adjustment.
2. Set your transceiver to middle channel (CH20). Press the PTT (push-to-talk) switch, and tap the antenna (making it shorter). The S.W.R meter will show a lower reading each time the antenna is tapped. By continuing to shorten the antenna, you will notice the S.W.R reading will reach a low point and then start rising again. This means that you have passed the optimum point for Channel 20.

Extend the antenna a short distance and again follow the procedure above. When the lowest point has been reached, switch to low channel (CH1) and then to high channel (CH40) and compare S.W.R readings. They should be almost equal.

NOTE

The proper setting is achieved when the SWR is 1.5 or below, and when it has the same reading for low and high channels.

B. Antennas which must be cut to proper length

1. Follow the same procedure as above but adjust the length by cutting in 1/8" increments until a good match is obtained.
2. Be very careful not to cut too much at one time, as one it is cut, it can no longer be lengthed.
3. The whip is easily cut by filing a notch all the way around and breaking the piece off with pliers.

If you're having difficulties in adjusting your antenna, check the following:

- a. All doors must be closed when adjusting the antenna
- b. Make sure the antenna base is grounded.
- c. Check your coaxial cable routing (it may be pinched when routed into the car)
- d. Try a different location in your car (keeping in mind the radiation pattern you wish.)
- e. Is the antenna perfectly vertical?
- f. Try a different location in your neighborhood. Stay away from large metal objects when adjusting (metal telephone polls or light post, fences, etc.)

NOTE

The transceiver will operate into an SWR of 2 to 1 indefinitely and sustain an SWR of 20 : 1 for a maximum of 5 minutes at rated operating conditions.

EXTERNAL SPEAKER

The external speaker jack (EXT SP.) on the rear panel is used for remote receiver monitoring. The external speaker should have 8 ohms impedance and be able to handle at least 4 watts. When the external speaker is plugged in, the internal speaker is disconnected.

CHAPTER 3 OPERATION

FRONT PANEL

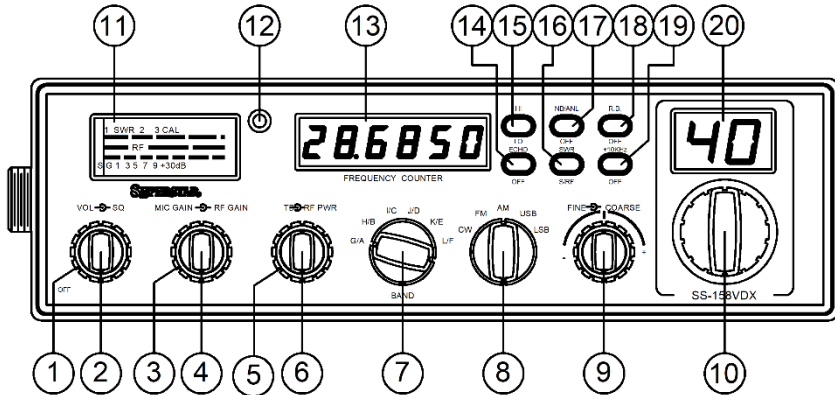

- 1. SQUELCH CONTROL :** This switch is used to eliminate background noise being heard through the receiver which can be disturbing when no transmission are being heard through the received. To use this feature, turn the switch fully counterclockwise and then turn clockwise slowly until the background noise is just eliminated. Further clockwise rotation will increase the threshold level which a signal must overcome in order to be heard. Only strong signal will be heard at a maximum clockwise setting.
- 2. ON/OFF VOLUME CONTROL :** This knob controls the volume and power to the radio. To turn radio on, rotate the knob clockwise. Turning the knob further will increase the volume of the receiver.
- 3. RF GAIN CONTROL :** This control is used to reduce the gain of the RF amplifier under strong signal conditions.
- 4. MIC GAIN CONTROL :** Adjust the microphone gain in the transmit modes. This controls the gain to the extent that full talk power is available several inches away from the microphone
- 5. RF POWER :** This control enables adjustment of RF power output continuously up to the rated output power.

6. **TALKBACK/OFF CONTROL:** Adjust this knob for desired volume of Talkback. This is used to monitor your own voice. Or example, you could use this feature to compare different microphones.
7. **BAND SELECTOR :** This band selector allow the user to select the desired band.
8. **MODE CONTROL :** This control allows you to select one of the following operating modes : CW/FM/AM/USB/LSB.
9. **FINE/COARSE CONTROL :** Allows variation of the receive operating frequency above or below the assigned frequency. Although this control is intended primarily to tune in SSB/CW signals, it may be used to optimize AM/FM signals as described in the Operating Procedure paragraphs. Coarse operates both TX/RX but Fine only in RX.
10. **CHANNEL SELECTOR :** This control is used to select a desired transmit and receive channel.
11. **FRONT PANEL METER/TX LIGHT :** The Front Panel Meter allows the user to monitor signal strength, RF output power and SWR level. The red LED indicates the unit is in the transmit mode.
12. **AUTO DIM CONTROL :** This function with light sensor control. The channel display, meter and counter light will changing with environment condition.
13. **FREQUENCY COUNTER :** This frequency counter indicates the selected channel frequency digitally.
14. **ECHO SWITCH:** This control is used for echo effect.
15. **HI/LOW SWITCH :** This switch select HI or LOW band of operation.
16. **S-RF/SWR/ SWITCH :** In the S-RF position, the meter swings proportionally to the strength of the received signal. When transmitting, the meter indicates relative RF output power. When in the SWR position, the standing wave ratio is measured.
17. **NB/ANL/OFF SWITCH :** When the switch is place in the NB/ANL position, the RF Noise Blanker (NB) and the Automatic Noise Limiter (ANL) in the audio circuits are activated. The Noise Blanker is very effective in eliminating repetitive impulse noise such as ignition interference.

- 18. **ROGER BEEP** : When this switch is placed in the ROGER BEEP position, the radio automatically transmits an audio tone at the end of your transmission. This indicates the end of your transmission so that people who are having trouble hearing you will know that you are done speaking. As a courtesy to others, use the Roger Beep only when necessary.
- 19. **+10KHz SWITCH** : In the +10KHz position, the transmit and receive frequency is shifted 10 KHz up.
- 20. **CHANNEL DISPLAY** : The channel display indicates the current selected channel.

REAR PANEL

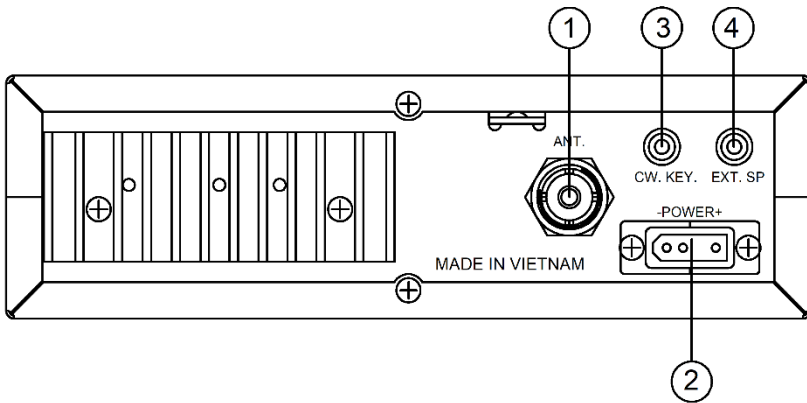

- 1. **ANTENNA** : This jack accepts 50 ohms coaxial cable with a PL-259 type plug.
- 2. **DC POWER** : This accepts 13.8V DC power cable with built-in fuse. The power cord provided with the radio consist of a black wire (negative) and a red wire (positive).
- 3. **CW. KEY** : This jack is for Morse Code operation. To operate, connect a CW Key to this jack and place the Mode Control in the CW position.
- 4. **EXT. SP** : This jack accepts 4 to 8 ohms, 5 watts external speaker. When the external speaker is connected to this jack, the built-in speaker will be disabled.

PROCEDURE TO RECEIVE AND TRANSMIT

A. MICROPHONE

The receiver and transmitter are controlled by the push-to-talk switch on the microphone. Press the switch and the transmitter is activated, release switch to receive. When transmitting, hold the microphone two inches from the mouth and speak clearly in a normal voice. This transceiver comes complete with a low impedance dynamic microphone.

B. PROCEDURE TO RECEIVE

1. Be sure that power source, microphone and antenna are connected to the proper connectors before going to the next step.
2. Turn **VOL** knob clockwise to apply power to the radio.
3. Set the **VOL** for a comfortable listening level.
4. Set the **MODE** switch to the desired mode.
5. Listen to the background noise from the speaker. Turn the **SQ** knob slowly clockwise until the noise just disappears. The **SQ** is now properly adjusted. The receiver will remain quiet until a signal is actually received. Do not advance the control too far or some of weaker signals will not be heard.
6. Set the **CHANNEL** selector switch to the desired channel.
7. Set the **RF GAIN** control fully clockwise for maximum RF gain.
8. Adjust the **FINE/COARSE** control to clarify the SSB/CW signals or to optimize AM/FM signals.

C. PROCEDURE TO TRANSMIT

1. Select the desired channel of transmission
2. Set the **MIC GAIN** control fully clockwise.
3. If the channel is clear, depress the push-to-talk switch on the microphone and speak in a normal voice.

RECEIVING SSB SIGNALS

There are four types of signals presently used for communications in the Citizens Band : FM, AM, USB and LSB. When the MODE switch on your unit is placed in the AM position, only standard double-side band and in FM position, only frequency deviation, full carrier signals will be detected. An SSB signal may be recognized while in the AM or FM mode by its characteristic "Donald Duck" sound and the inability of the detector to produce an intelligible output. The USB and LSB modes will detect upper side band and lower side band respectively, and standard AM signals.

SSB reception differs from standard AM reception in that an SSB receiver does not require a carrier or opposite side band to produce an intelligible signal. A single-side band transmitted signal consists only of the upper or the lower side band and no carrier is transmitted. The elimination of the carrier from the AM signal helps to eliminate the biggest cause of whistles and tones heard on channels which make even moderately strong AM signals unreadable. Also, SSB takes only half the space of an AM channel, therefore two SSB conversations will fit into each channel, expanding the 40 AM channels to 80 SSB channels. The reduction in channel space required also helps in the receiver because only half of the noise and interference can be received with 100% of the SSB signal.

An SSB signal may be received only when the listening receiver is functioning in the same mode. In other words, an upper side band signal (USB) may be made intelligible only if the receiver is functioning in the USB position.

If a lower side band (LSB) signal is heard when the receiver is in the USB mode, no amount of tuning will make the signal intelligible. The reason for this may be understood if you consider that when the modulation is applied to the transmitter's microphone in the USB mode, the transmitter output frequency is increased whereas in the LSB mode the transmitter's output frequency is decreased.

The result in listening to the receiver is that when the MODE switch is in the proper position (either USB or LSB), a true reproduction of a single tone of modulation will result, and if the tone is increased in frequency (such as a low-pitched whistle or a high-pitched whistle) you will hear the increase in the output tone of the receiver. If the incorrect mode is selected, an increase in tone of a whistle applied to the transmitter will cause a decrease in the resultant tone from the receiver.

Thus when a voice is used in place of a whistle or tone, in the proper listening mode the voice will be received correctly whereas in the incorrect mode, the voice will be translated backwards and cannot be made intelligible by the FINE/COARSE control. When listening to an AM transmission, a correct side band is heard in either mode since both upper and lower side bands are received.

Once the desired SSB mode has been selected, frequency adjustment may be necessary in order to make the incoming signal intelligible. The FINE/COARSE control allows the operator to vary frequency above or below the exact frequency of the channel. If the sound of the incoming signal is high or low pitched, adjust the operation of the FINE/COARSE.

Consider it as performing the same function as a phonograph speed control. When the speed is set too high, voices will be high-pitched and if set too low, voice will be low-pitched. Also, there is only one correct speed that will make a particular record produce the same sound that was recorded. If the record is played on a turntable that is rotated in the wrong direction (opposite side band) no amount of speed control (FINE/COARSE) will produce an intelligible sound.

An AM signal received while listening in one of the SSB modes will produce a steady tone (carrier) in addition to the intelligence, unless the SSB receiver is tuned to exactly the same frequency by the FINE/COARSE control. For simplicity, it is recommended that the AM modes be used to listen to AM signals.

ALTERNATE MICROPHONES AND INSTALLATION

For best results, the user should select a low-impedance dynamic type microphone or a transistorized microphone. Transistorized type microphones have low output impedance characteristics. The microphones must be provided with a four-lead cable. The audio conductor and its shielded lead comprise two of the leads. The third lead is for transmit control and fourth is for receiving control.

The microphone should provide the functions shown in schematic below.

4 WIRE MIC CABLE

<u>Pin Number</u>	<u>Mic Cable Lead</u>
1	Audio Shield
2	Audio Lead
3	Transmit Control
4	Receive Control

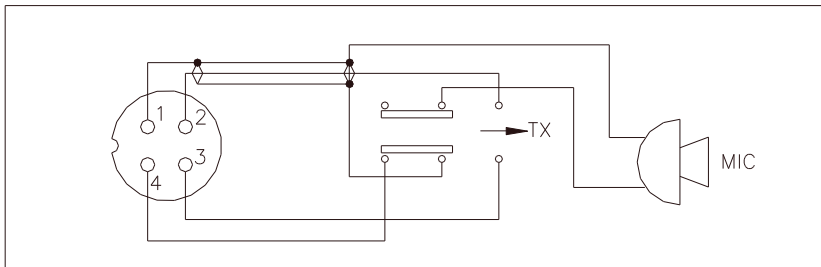

Fig. 1 Your transceiver microphone schematic.

If the microphone to be used is provided with precut leads, they must be revised as follows.

1. Cut leads so that they extend 7/16" beyond the plastic insulating jacket of the microphone cable.
2. All leads should be cut to the same length. Strip the ends of each wire 1/8" and tin the exposed wire.
3. Before beginning the actual wiring, read carefully the circuit and wiring information provided with the microphone you select. Use the minimum heat required in soldering the connections. Keep the exposed wire lengths to a minimum to avoid shorting when the microphone plug is reassembled.

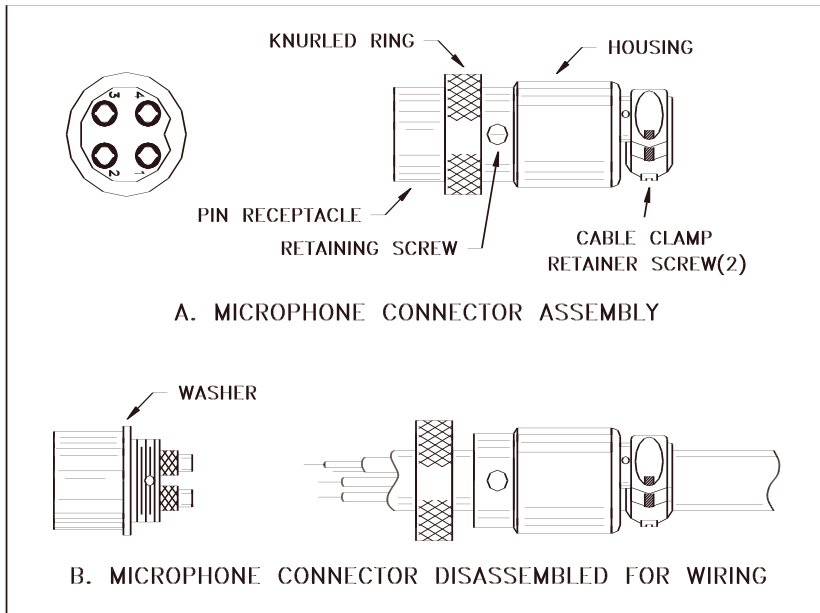

Fig. 2 Microphone plug wiring

To wire the microphone cable to the plug provided, proceed as follows :

1. Remove the retaining screw.
2. Unscrew the housing from the pin receptacle body.
3. Loosen the two cable clamp retainer screws.
4. Feed the microphone cable through the housing, knurled ring and washer as shown Figure 2.
5. The wires must now be soldered to the pins as indicated in the above wiring tables. If a vise or clamping tool is available it should be used to hold the pin receptacle body during the soldering operation, so that both hands are free to perform the soldering. If a vise or clamping tool is not available, the pin receptacle body can be held in a stationary position by inserting it into the microphone jack on the front panel. The numbers of the microphone plug are shown in Fig. 3, as viewed from the back of the plug. Before soldering the wire to the pins, pre-tin the wire receptacle of each pin of the plug.

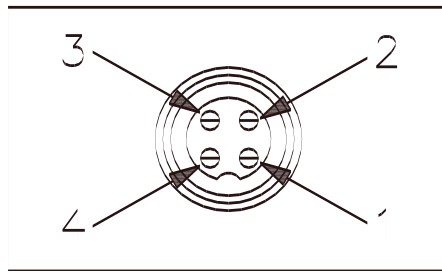

Fig. 3 Microphone plug pin numbers viewed from rear of pin receptacle.

6. Be sure that the housing and the knurled ring of Figure 2 are pushed back onto the microphone cable before starting to solder. If the washer is not captive to the pin receptacle body, make sure that it is placed on the threaded portion of the pin receptacle body before soldering.
7. If the microphone jack is used to hold the pin receptacle during soldering operation, best results are obtained when the connections to pin 1 and 3 are made first and then the connections to pins 2 and 4. Use a minimum amount of soldering and be careful to prevent excessive solder accumulation on pins, which could cause a short between the pin and the microphone plug housing.
8. When all soldering connections to the pins of the microphone are completed, push the knurled ring and the housing forward and screw the housing onto the threaded portion of the pin receptacle body. Note the location of the screw clearance hole in the plug housing with respect to the threaded hole in the pin receptacle body. When the housing is completely threaded into the pin receptacle body, a final fraction of a turn either clockwise or counterclockwise may be required to align the screw hole with the threaded hole in the pin receptacle body. When these are aligned, the retaining screw is then screwed into place to secure the housing to the pin receptacle body.
9. The two cable clamp retainer screws should now be tightened to secure the housing to the microphone cord. If the cutting directions have been carefully followed, the cable clamp should secure to the insulation jacket of the microphone cable.
10. Upon completion of the microphone plug wiring, connect and secure the microphone plug in the transceiver.

Memo



A series of 16 horizontal lines spaced evenly down the page, providing a template for writing a memo.

Memo

[Redacted header bar]

Printed in VIETNAM
AT148N091B